

Datalogic Automation Machine Vision at a glance	4
Automotive	6
Electronics	8
Packaging	10
Medical & Pharma	12
General Manufacturing	14
Impact software: VPM and CPM	16
Impact Lite software	18
Tools and Controls	20
Machine vision basic principles	24
Smart cameras	28
Vision processors	30
Digital cameras	32
Accessories	34
Training and Support	35



MACHINE VISION

The Machine Vision Business Unit of Datalogic Industrial Automation is built upon the acquisition of PPT Vision Inc. in 2011. For over 30 years, PPT Vision has focused exclusively on the development of machine vision technology for in-line automated inspection and factory automation. Thanks to its extensive experience of thousands of successful machine vision installations throughout the world, PPT has become a recognized world leader in machine vision innovation and has brought unique benefits to customers:

- **A single machine vision software platform** - Programming software that is flexible, powerful, and common to all smart cameras and embedded vision system products. This means no operator cross-training and no need to maintain different software platforms— just select the hardware you want and go! Transfer inspection programs from one camera to another and back again without redeveloping the application.
- **Flexibility and Security** – Control Panel Manager (CPM) - a control panel software that is not only secure, but field-configurable and common to all products. Protect your inspection and system configuration from unauthorized users, but allow qualified personnel as much flexibility as they need. CPM provides ultimate flexibility when compared to complicated software programming languages and allows you to create control panels in a mere fraction of the time. Connect and view data from one or many vision systems with just a click of a button.

- **Time-to-market** - Personalized, technically superior and committed customer support. We can provide you with as much support as you need when it comes to delivering application solutions. Choose one of our highly skilled and qualified application engineers or training specialists, or select a certified partner to guide you from application concept to installation and qualification of your system.
- **Large product portfolio** - Hardware platforms that allow our customers to expand their range of applications. From stand-alone compact smart cameras to the highest performance embedded processors, we can deliver a vision system optimized for your inspection needs. Choose a smart camera in an inline or right angle version, color or greyscale sensor, CCD or CMOS sensor; it does not matter because we have you covered. For vision processors, select from a single to multi-headed area scan or line scan cameras that range from VGA to ultra-high resolution images.

Today, after completion of the integration process between Datalogic Industrial Automation and PPT Vision Inc., the combined product lines of the two companies encompasses both hardware and software while covering a wide range of performance and price point requirements. Selling through a global network of experienced distributor and integration partners, Datalogic Automation is the complete solution provider for all your machine vision needs.

TIMELINE

1982	1984	1991	1991	1994	1997	1997	2000	2001	2002	2002
Founded as Pattern Processing Technologies	APP 200 Series Vision System Introduced	Vision Process Controller (VPC) Product Released	Vision Program Manager (Classic) Software Released	PPT Vision releases the Passport Scout Product Lineup	PPT Acquires 3D Scanning Moiré Interferometry (SMI) Technology	DSL Vision System Introduced – World's First Full Digital Vision System	Microelectronics Product Group (MPG) Developed	PPT 861 3D Product released for Semiconductor Business	IMPACT C – Series Tethered Smart Camera Product Introduced	IMPACT Software Suite Released (Vision Program Manager & Control Panel Manager)

TECHNOLOGY



MACHINE VISION PRODUCT GROUPS

- Smart Cameras
- Vision processors
- Machine Vision Software

Our complete family of high-performance smart cameras and embedded machine vision systems utilize the same software across all products. The hardware consists of smart cameras, and embedded vision systems. These products are specifically designed and developed by our engineers to meet all your manufacturing inspection requirements and to get your application up and running faster than anyone else in the industry – Guaranteed!

INNOVATION

Through continuous development and refinement, our product line is the most complete hardware and software solution available on the market today.

EXPERIENCE

With 30 years in the machine vision business and thousands of successful customer installations, our organization and your partners are able to solve the most challenging inspection applications within a wide variety of markets and manufacturing settings.

RESPONSIVENESS

Together with our global distribution and integration partners, pride our self on providing a level of training and support that is unmatched in the industry. We listen, then execute – turning our customers' requirements into solutions faster than anyone else.

2003	2003	2004	2005	2006	2007	2010	2011	2012	2013	2014	2015	2016
Integrates CameraLink into C-Series Processor	OCR Software Released	IMPACT T-Series Inline Smart Camera Introduced	Datalogic SCS1 Smart Camera Introduced	IMPACT A-Series Right Angle Smart Camera Introduced	Datalogic DataVS Vision Sensor introduced	MX40 Multi camera vision processor Introduced	PPT Vision acquired by Datalogic	PPT Vision Inc. becomes the Machine Vision BU of Datalogic Industrial Automation	A30 and T4x-Series Smart Camera Introduced	P-Series Smart Camera Introduced	MX-U Vision Processor Introduced	MX-E Vision Processor Introduced



AUTOMOTIVE

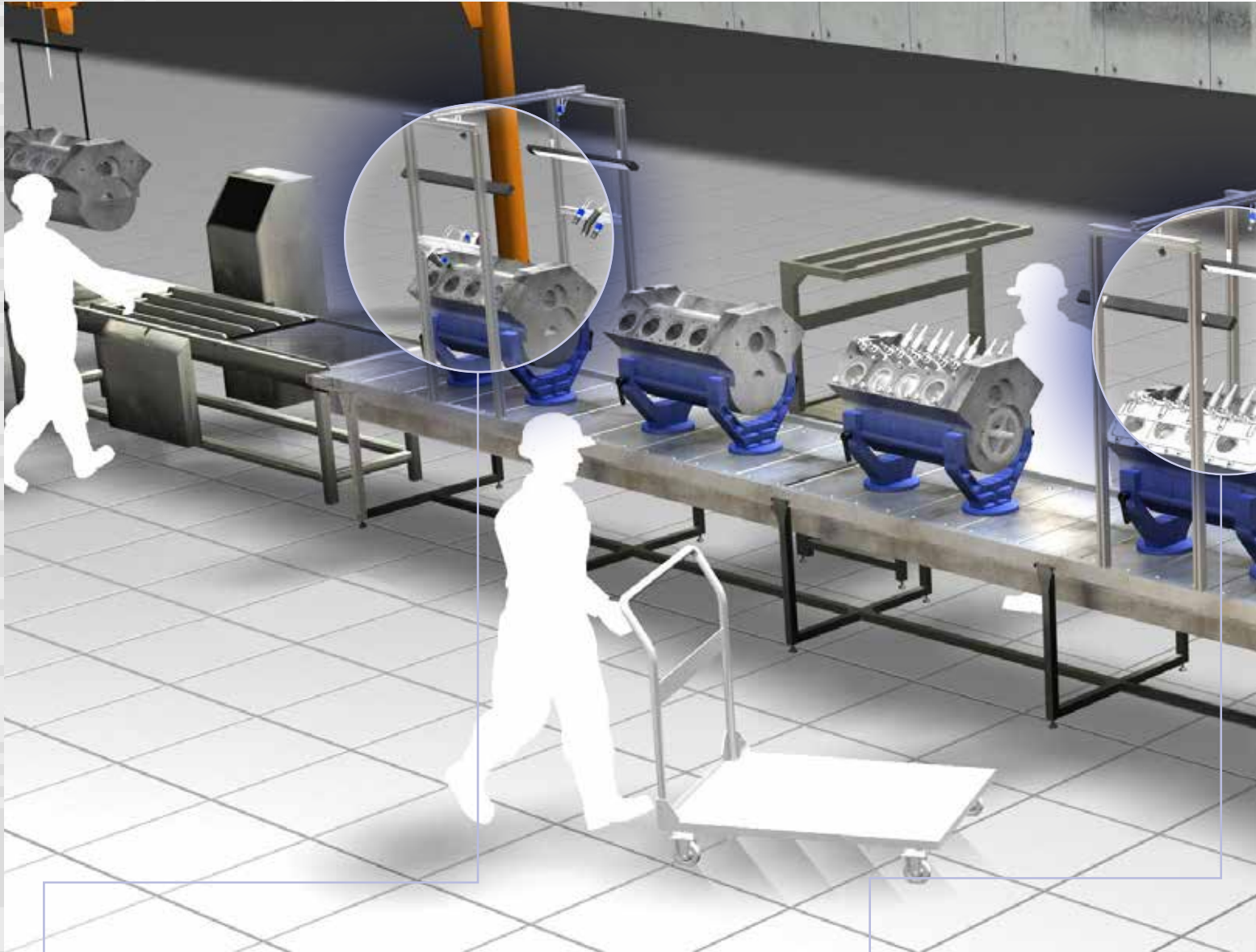

ENGINE BLOCK VERIFICATION



Allows manufacturers to verify and quantify the proper placement and size of critical bolt hole locations as well as to identify if secondary processes, such as thread tapping or surface machining, have been successfully completed. This type of early inspection prevents the manufacturer from adding more cost to defective materials or allows for the identification of flawed high value parts that can be reworked.

EPOXY BEAD VERIFICATION

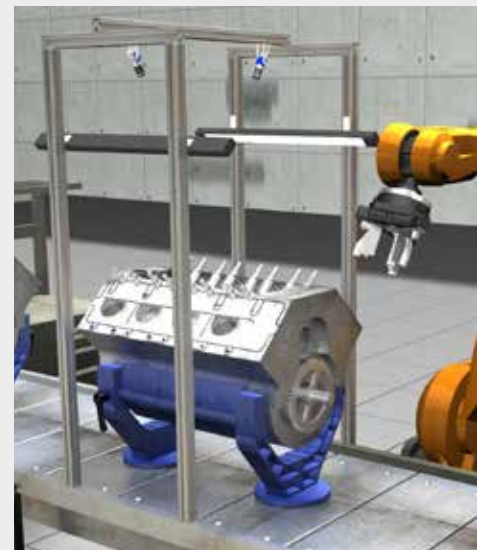

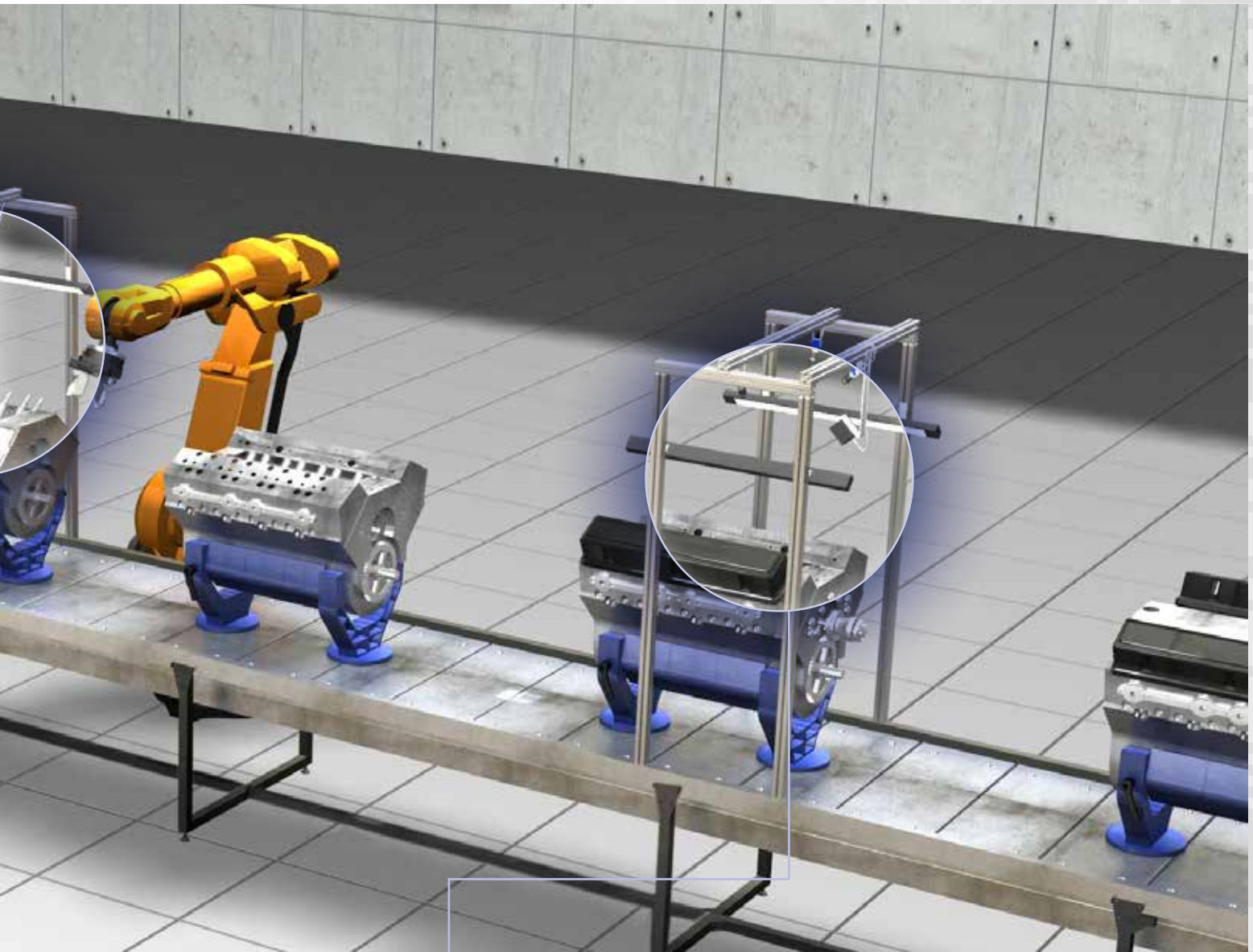

ON



This verification checks for the proper placement, shape or quantity of a sealant or epoxy bead on a surface that will be mated with other critical surfaces or components. Damaged or improperly formed beads, identified by the system, can also indicate issues with the bead application process. Early identification of these problems can provide huge savings to the manufacturer as well reduced quality issues to the customer.

COMPONENT PRESENCE / POSITION



This inspection eliminates the need for manually verifying single or multiple features or components on a single assembly. These features may include proper orientation, right size or correct color as well as the ability to confirm multiple product configurations or variations. The benefit of 100% inspection, provided by the vision system, insures only the properly assembled product gets to the customer.

ELECTRONICS



RAW MATERIAL INSPECTION

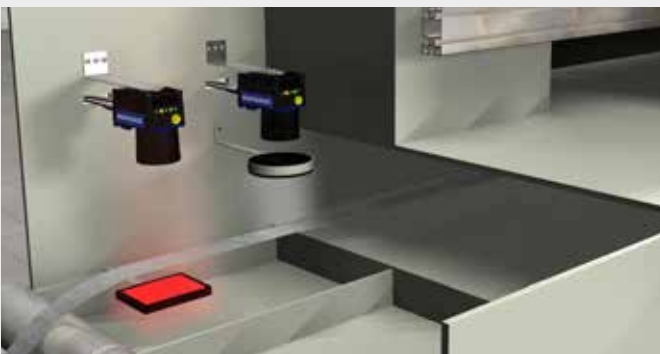

The pre-process inspection allows for inspection of raw material prior to secondary processing. This eliminates adding value to low quality material. In connector manufacturing, the strip width and pilot hole locations are critical to the process. Likewise, surface defects such as porosity, stains and scratch inspection is critical to the final product.

GOLD PLATING INSPECTION

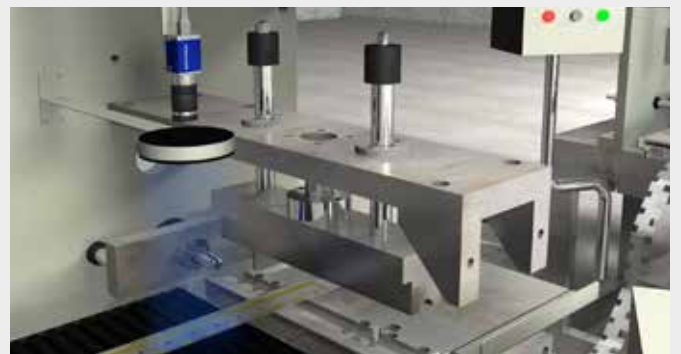

Post plating inspection provides assurance that highly value material such as gold is accurately placed in the correct position on the brass strip. 100% inspection of the plating allows the operator to monitor the process and make on the fly corrections to the high value continuous product with little or no downtime as well as low waste of processed material.



TRIMMED MATERIAL INSPECTION



Post stamping inspection verifies 100% dimensional tolerance acceptance on internal features that cannot be inspected, without destructive methods, after the secondary forming or assembly is completed. Other types of inspections that can be addressed simultaneously include burr detection and secondary plating inspection.

INSERT MOLDING INSPECTION



Insert molding inspection allows for verification of properly formed molded plastic housings as well as performing final measurement checks on critical dimensions of the connector. This inspection identifies areas of material shortage as well as excess material that can cause non sealing or locking conditions or excessive connector insertion forces.

PACKAGING



POST BAKING INSPECTION



This high speed inspection checks for the consistency of food products after coming out of the baking or frying process to guarantee the food is not over cooked or discolored and reducing customer complaints.

FRUIT CLUMP DETECTION



Clump detection identifies when certain types of food stick together to form large masses of food. Masses of food may not be fully processed or cooked, too large for the subsequent process and ultimately cause large amounts of waste or possible health concerns by being under processed.

CONTENT FILL AND MIX INSPECTION



The content fill inspection provides assurance that the product is properly placed in the package and verifies the presence of any secondary components before the sealing of the package. With a properly configured system additional information such as product fill height can also be determined. These inspections help to guarantee the customer always receives the correct amount of product.

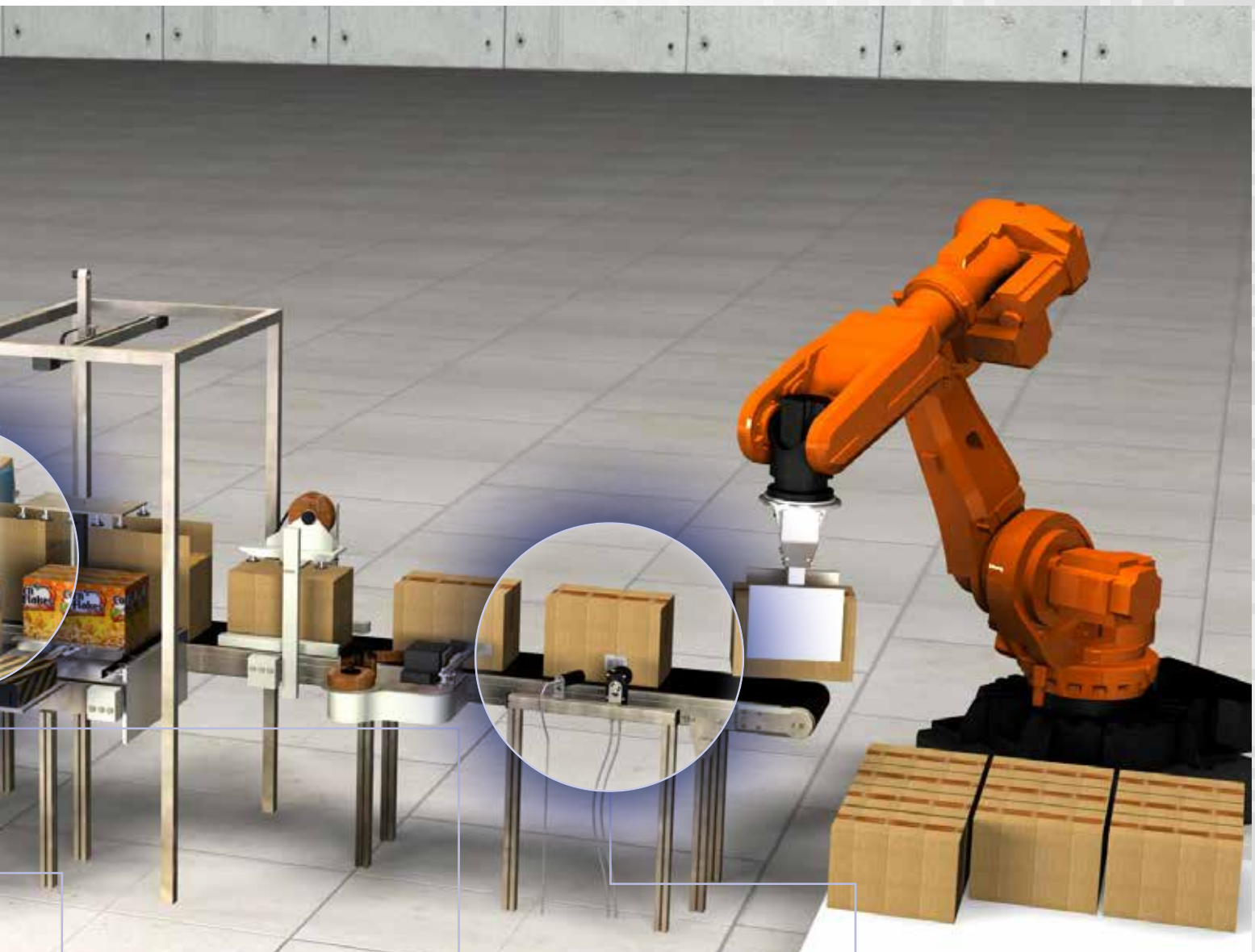

OPEN FLAP DETECTION



Flap detection verifies all of the flaps on a box food package are fully formed and sealed to insure freshness of the product as well as uniform shape for secondary packing of the product and a positive visual effect for the customer.

EXPIRATION DATE PRESENCE



100% verification of date and lot codes and code quality can be accomplished with machine vision at extremely high rates of speed. This allows for traceability and regulation requirements of food products.

LABEL INSPECTION



Verifying the different variables on a label (e.g. product weight, cost, ingredients and current promotions) can be accomplished through the use of optical character recognition (OCR) as well as reading barcodes to identify product contents. This feature is especially important when tracking products that contain allergens or require the presence of other health related information on the label.

MEDICAL & PHARMA

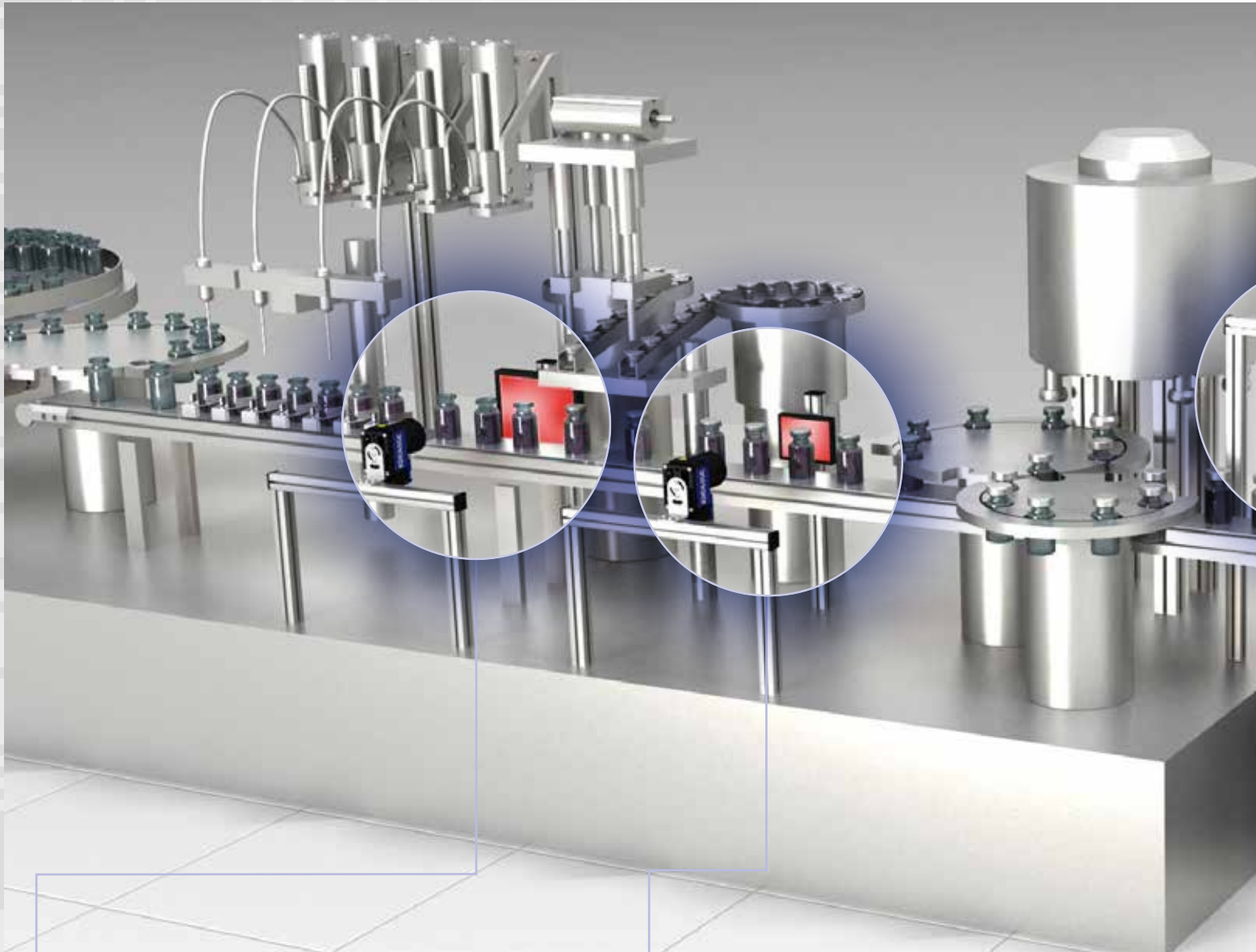

LIQUID LEVEL INSPECTION



This inspection provides for the amount of liquid in transparent bottles and can be done quickly and effectively through the use of machine vision. Properly applied, this inspection ensures the bottle is filled to specification while eliminating waste and costs associated with overfill or under fill conditions.

CAP INSPECTION



This inspection ensures the product quality by verifying the bottle cap is present and applied correctly. Normally, this inspection is performed at high rates of speed prior to the sealing and final packaging process where visual inspection is not possible without reopening the sealed package.

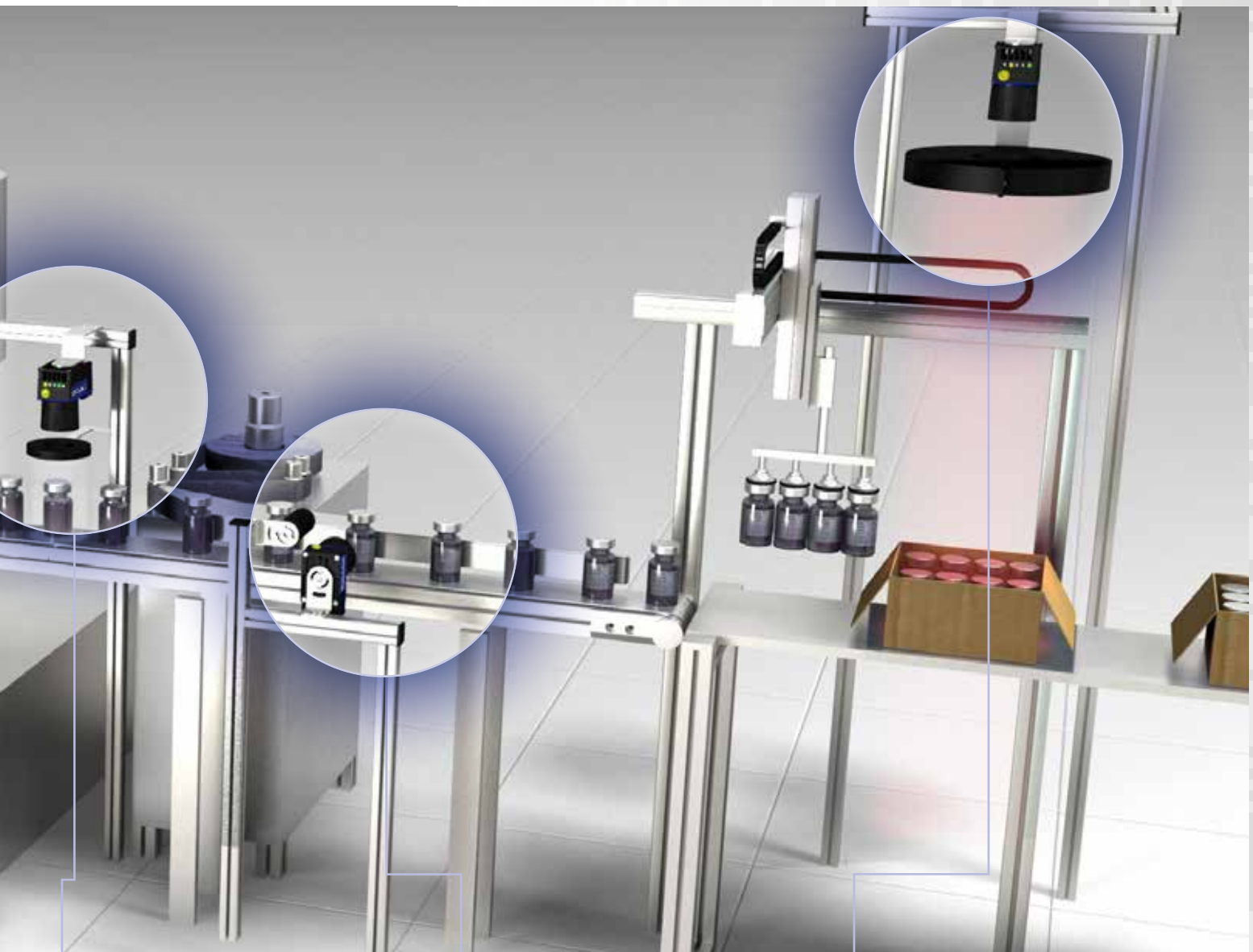

SAFETY SEAL INSPECTION



Verifies the product is protected with a properly applied tamper proof seal before leaving the factory or a clean area within the manufacturing facility. Ultimately, this inspection eliminates product contamination through the packaging integrity of the product.

LABEL INSPECTION



Checking for critical variable product information on labels (including product weight, ingredients, warnings, etc.) can be accomplished through the use of optical character recognition (OCR), barcode or matrix code readers – all available on smart cameras and vision systems. This feature is especially important when tracking products that contain materials that are ingested or require the presence of other health related information to be printed on the product label.

BOX INSPECTION



Allows the user to check for and verify the completeness of product packaging. This includes verification of the product count, product type and any miss-packaged or damaged items inside the product carton.

GENERAL MANUFACTURING

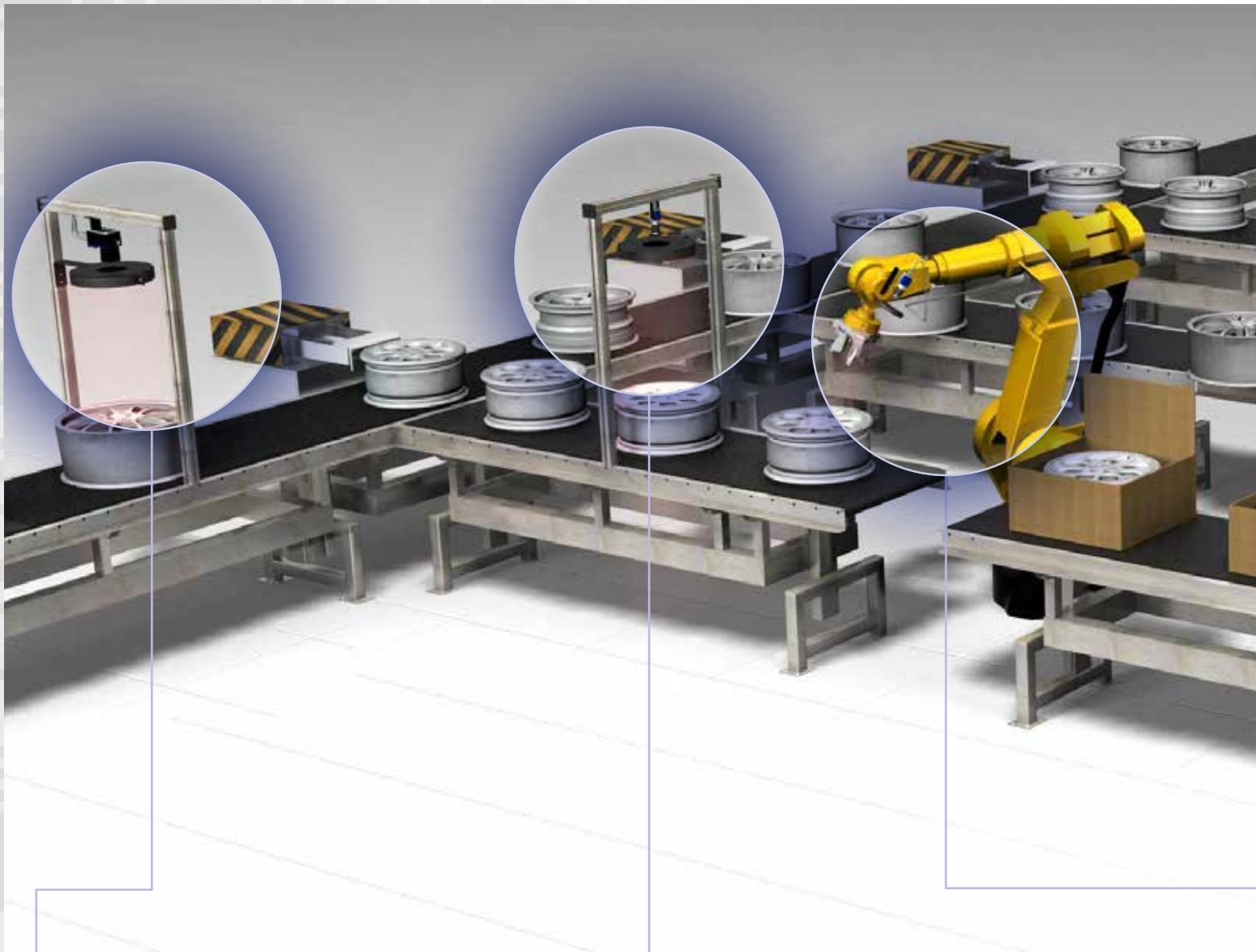

RIM SORTING

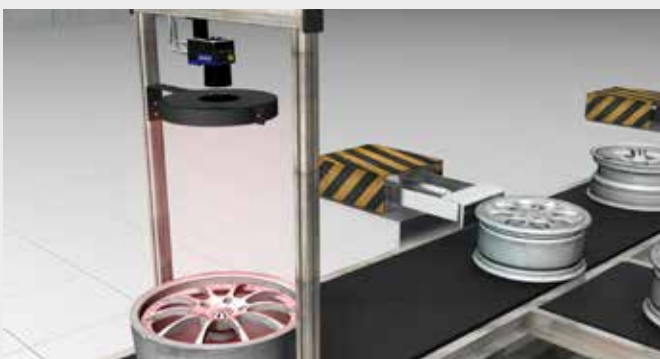

The vision system determines the product model by gross physical characteristics of the inspected rim. In this particular inspection, the key characteristics are the spoke pattern and product diameter. This type of inspection allows for more automation, which in turn, reduces added potential product damage by manual handling and increases the production rates through higher line efficiency.

RIM INSPECTION



This vision system verifies the surface quality and inspects critical dimensions of key features. These inspections reduce any human subjectivity and collect process information that can be used to identify problem areas in the manufacturing line. This captured data is used for further analysis of the process and ultimately problem resolution, reducing costs related to returned products from unsatisfied customers.



RIM ROBOT GUIDANCE



The vision system identifies the position and orientation of the rim to allow the robot to position itself correctly for picking up the rim. This type of guidance prevents damage to the rim due to incorrectly aligned fixtures on the robot.

LABEL INSPECTION



The vision system verifies the printed label matches the current product and ensures the label is readable for transportation and customer identification. This inspection prevents the return of incorrectly labeled parts from the customer and ensures stocking accuracy reducing costs related to miss marked parts.

IMPACT SOFTWARE

Impact Software Suite, with over 120 inspection tools and 50 user interface controls, allows users to create unique inspection programs and develop user interfaces quickly and easily.

All this can be done without the loss of flexibility, like traditional configurable systems, or the need for vast amounts of development time like traditional SDK environments.

VISION PROGRAM MANAGER (VPM)



Vision Program Manager (VPM) provides hundreds of image processing and analysis functions. Use VPM to enhance images, locate features, measure objects, check for presence and read text and bar codes.

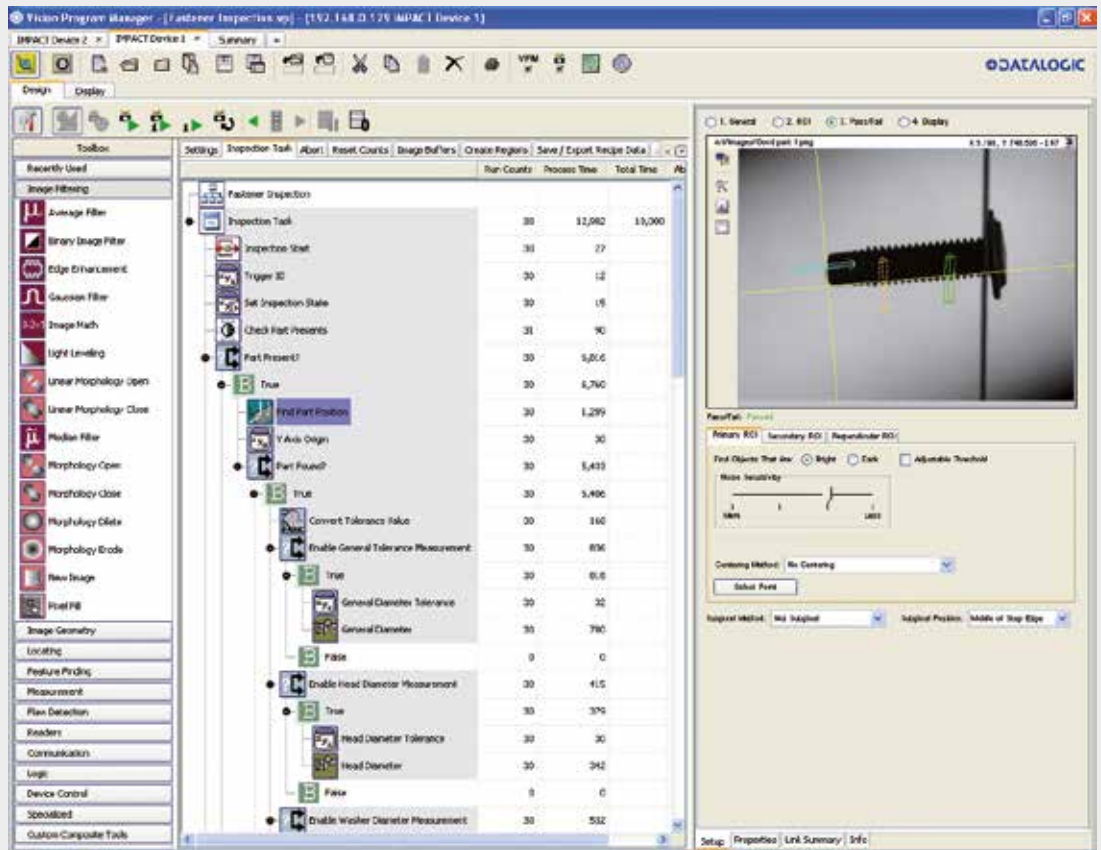

FEATURES AND BENEFITS

One software fits all

The entire range of smart cameras and vision processors can be configured through the Impact Software suite. Users need only learn one program thus shortening their learning curve. Once developed, the same application can be used on different hardware platforms with no modifications or reprogramming.

Ease-of-use

Impact Software suite is a graphical user interface where no programming is required. Neither VPM nor CPM forces a user to write code. Rather, developers need only to drag-and-drop tools into the tree view and set parameters. Thanks to the embedded emulator, settings can be tested immediately with images previously stored on the PC.

Wide range of controls

With more than 120 controls, Impact is one of the most complete machine vision software suites available on the market. Image filtering, calibration, feature locating, flaw detection, measurement, and code reading are just few examples of the wide range of tools available which allow users to solve even the most challenging applications.

Control Panel Manager (CPM)

Developers can easily create a customized user interfaces thanks to Control Panel Manager (CPM). This software allows users to build up full HMI's just by dragging and dropping controls onto a panel. Authorized operators have the possibility to check images, results and statistics as well as to adjust or modify the working parameters of inspection tasks.

Impact Software powers the full line of integrated vision solutions, from simple to complex. The investment in software and training is preserved as inspections grow. Programs for the same inspections

can be easily shared or transferred across multiple inspection points within the factory. *One software – countless applications!*

CONTROL PANEL MANAGER (CPM)



Control Panel Manager (CPM) simplifies development of operator interfaces while providing the ability to make on-the-fly adjustments to critical machine controls. Use CPM to create operator interface panels to view and adjust critical machine controls.

	Enable	Add In Dist.	Nominal	High	Low	Current
General Diameter:	<input checked="" type="checkbox"/>		0.500	0.008	0.008	0.170
Head Diameter:	<input checked="" type="checkbox"/>		1.035	0.020	0.020	0.365
Washer Diameter:	<input checked="" type="checkbox"/>		0.590	0.020	0.020	0.221
Head Height:	<input checked="" type="checkbox"/>	1.400	1.420	0.040	0.040	-0.405
Major Diameter:	<input checked="" type="checkbox"/>		0.000	0.625	0.005	0.222
Minor Diameter:	<input checked="" type="checkbox"/>		0.000	0.530	0.005	0.180
Spiral Detection:	<input checked="" type="checkbox"/>			0.050	0.000	0.017
Length:	<input checked="" type="checkbox"/>	1.561	2.350	0.020	0.020	-0.207

HIGHLIGHTS

- **Easy to understand**, tree-view logic flow
- Tool Setups guide users through **step-by-step tool configuration**
- Includes **inspection and user interface development programs** as well as a runtime user interface
- Runs on **all smart camera and vision processor platforms**
- Provides **complete programmatic or manual control of hardware settings**
- Provides **real time parameter changes of cameras**
- **Controls and displays images and data** from multiple smart cameras or vision processors
- **Password protection** allows only authorized users to make changes
- **Built-in Emulator** saves time when creating, testing and debugging your vision program without a camera
- Software easily communicates with **higher level control system via TCP/IP, Ethernet/IP, Modbus and OPC protocols.**



IMPACT LITE SOFTWARE

IMPACT LITE is the new software application that powers the P-Series Smart Cameras. Part of the Datalogic IMPACT Machine Vision Software Suite, IMPACT LITE redefines software functionalities delivering easier and

faster device programming while maintaining the traditional interface. With IMPACT LITE, application prototyping and deployment is quicker than ever with features like: drag and drop tools into the inspection tree, one

VISION PROGRAM MANAGER (VPM)

IMPACT LITE features a selection of the most commonly used inspection tools. This set of algorithms has been chosen by Datalogic specialists with 30+ years of experience to meet typical application requirements while keeping the device configuration quick and easy.

IMAGE FILTERING

- Edge Enhancement
- Morphology Dilate
- Morphology Erode

LOCATING

- Blob
- Circle Gauge
- Line Find
- Origin
- Pinpoint Pattern Find

FEATURE FINDING

- Average Intensity
- Blob
- Circle Gauge
- Color Blob
- Color Checker
- Contrast – Multiple ROI
- Edge Point Find
- Line Find
- Wide Edge Point Find

MEASUREMENT

- Circle Gauge
- Line Find
- Line Gauge
- Line Gauge Dual ROI
- Multiple Point to Point Measurements

FLAW DETECTION

- Average Intensity
- Blob
- Color Blob
- Contrast – Multiple ROI
- Greyscale Template

READERS

- Code Reader
- OCR*

COMMUNICATION

- Discrete Input
- Discrete Output
- EtherNet/IP Explicit Data
- EtherNet/IP Explicit Message
- EtherNet/IP Read Implicit
- EtherNet/IP Write Implicit
- Serial Port Out
- TCP/IP Port Out
- Image Archiving

LOGIC

- Counter
- Pass Fail
- Switch
- String Builder

P-SERIES

- Green Red Spot
- PROFINET IO Read
- PROFINET IO Write

*OCR tool is enabled with a separate license

EASE OF USE



Tool parameter setup with graphical controls



Single task configuration for simple application deployment and quick inspection debugging

click control linking, parameter adjustment with sliders and combo box controls.
 The P-Series Smart Camera combined with IMPACT LITE is ideal for

solution providers and automation engineers new to machine vision technology. The ultra-compact and cost effective camera solution provides both an easy-to-use device while delivering powerful inspection software.

VPM DISPLAY

IMPACT LITE software includes the VPM Display, a pre-configured monitoring software application that allows operators to supervise the quality control results as well as the machine vision device. The VPM display does not require programming or configuration; the panel is automatically generated when configuring the smart camera.

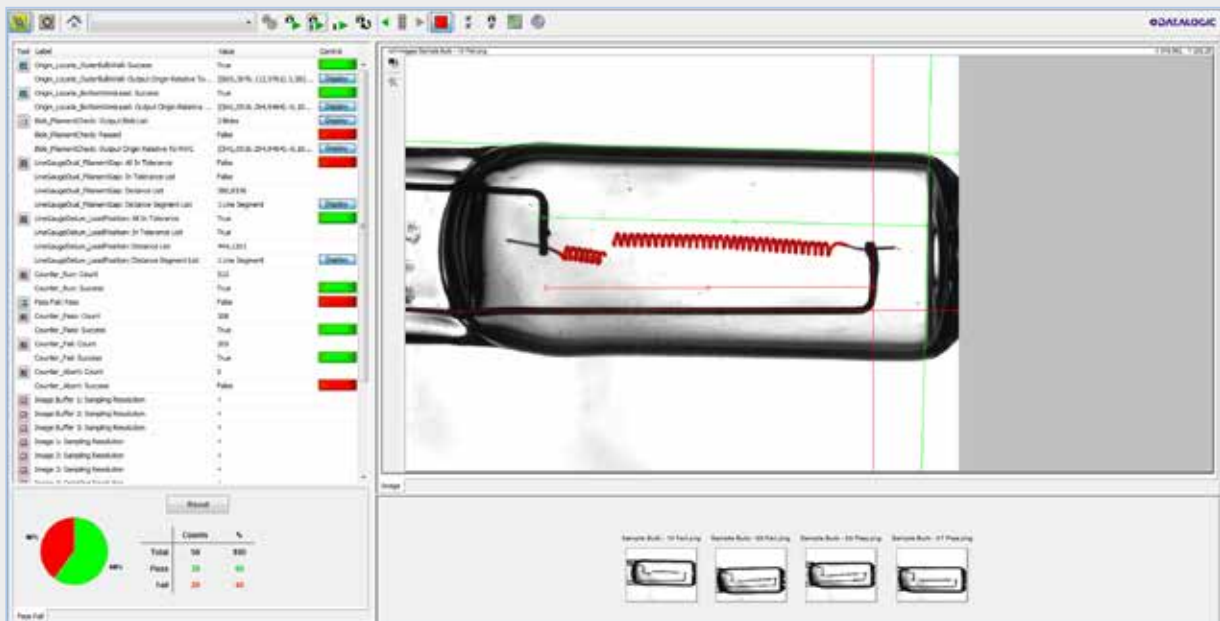

The VPM display offers full monitoring functionalities, such as:

- Live image displaying
- OK/NOK overall statistics
- Inspection switching
- Tool results (logic and numeric)
- Overlay graphic enable/disable
- Input setup



New Switch and String Builder tools to simplify logics and output data formatting

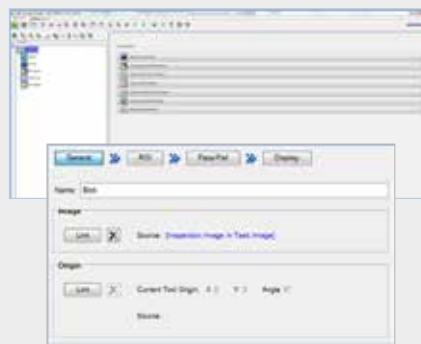

New panel look & feel improving the software usability and intuitiveness



FEATURE FINDING



- Detect presence/absence of objects
- Detect randomly oriented or amorphously shaped objects
- Verify whether an object grayscale or color is within acceptable range
- Identify edges of uniformly bright or dark objects
- Determine the sharpness of an edge through the use of gradient

FLAW DETECTION

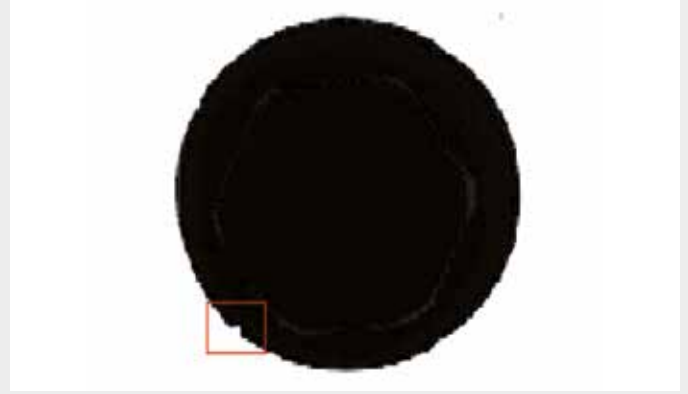

- Determine if objects are out of range
- Filter objects based on size and shape
- Detect differences between a trained object and run-time objects.
- Detect subtle defects in varying background
- Detect defects along the boundary edge of objects

LOCATE



- Use a locate tool to find the object itself or a feature within the object to use as a reference for other tools
- Edge detection to find the corner of an object
- Find the center of mass of an object
- Multiple pattern find tools can be used to find a trained pattern within the image in 360° rotation

IMAGE FILTERING



A complete set of image filtering tools available:

- Average, Median, Gaussian
- Morphology open, close, erode, dilate
- Edge enhancement
- Binarization
- Image subtraction
- Light leveling
- Pixel fill

COLORS

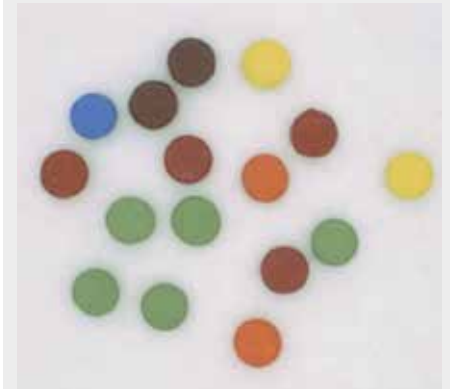

- Find randomly orientated or amorphously shaped colored objects
- Compare an object color with a trained color
- Color image offers red, green, blue, yellow, magenta, cyan and greyscale formats for use by other tools

MEASUREMENT

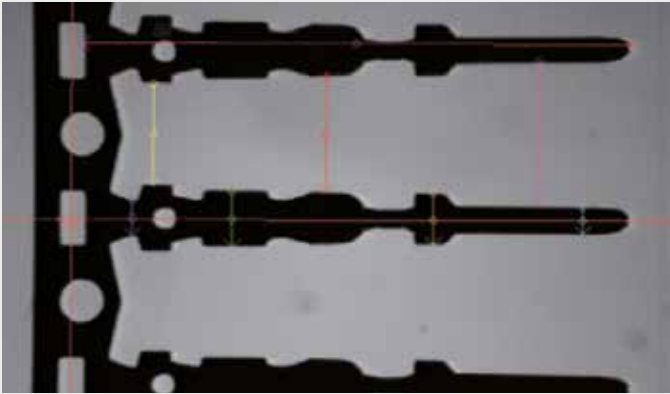

- Pixel or subpixel accuracies are possible
- Measure the angle between to linear objects
- Make multiple measurements within one tool
- Point to point and point to line measurements
- Measure radius, center, and concentricity of circular objects

CODE READERS & OCR



- State of the art 1D and 2D barcode readers. Find multiple codes within one image
- Extremely wide range of code symbologies supported
- Omni-directional code reading
- OCR – Optical Character Recognition – able to read character strings
- OCV – Optical Character Verification – able to verify if the content of a string matches with a trained one

LOGIC PROGRAMMING



- Tree-view programming structure allows for better tool organization and only run tools when requested
- Logic tools allow for decision-making capabilities without scripting
- Perform logical and mathematical calculations in a flexible and easy way

IMAGE CALIBRATION

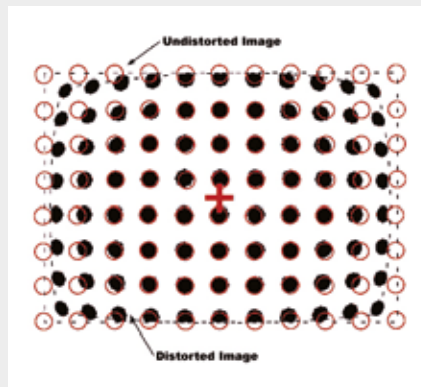

- Allows a user to remove perspective and radial distortion from an image as well as convert pixel to real world values
- Unwrap a curved object or correct a slanted object within an image (primarily used with OCR)
- Combine multiple images into one large image
- Reduce resolution by sampling the image

DATA COMMUNICATION

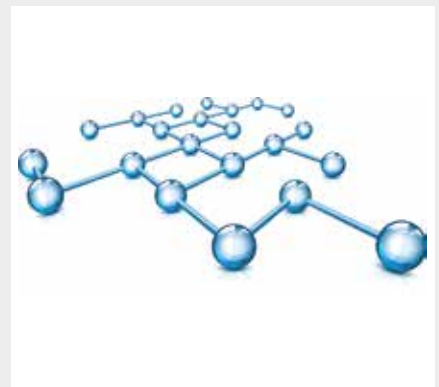

- Discrete I/O serial, TCP/IP, PROFINET IO and Ethernet/IP
- Supports HTTP, FTP and web serving protocols
- ActiveX controls available for 3rd party Microsoft® applications
- Modbus, PCCC and OPC server communication

PATTERN SORTING TOOL



The Pattern Sorting Tool (PST) is a revolutionary and unrivalled new pattern matching tool for sorting applications now available in the IMPACT Software Suite.

This state-of-the-art patented algorithm is able to find thousands of different patterns in an extremely effective way. The Pattern Sorting Tool guarantees maximum performances and consistency in any situation, even with objects poor of texture in cluttered fields of view.

This tool is a tremendous breakthrough in the machine vision industry as no algorithm is able to offer a reliable and robust recognition over such wide pattern databases today.

APPLICATIONS



Thanks to its capability to manage big databases of patterns, the PST is able to distinguish among thousands of different items manufactured or simply conveyed on the same line. The algorithm delivers robust recognition in any situation (e.g. 360° pattern rotations, perspective distortions, different scales and light variations).



The PST is not just a tool for item sorting. The algorithm can be used for many different purposes and applications. For instance it can detect the presence of stickers or logos as well as identify items by means of the artworks printed on the package.

PRODUCT HIGHLIGHTS

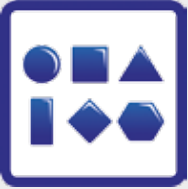

Large pattern database management

The PST is able to handle databases with thousands of different patterns. With the new Pattern Database Manager (PDM) software application, users can easily create new databases or edit existing ones.



Recognition of patterns with random orientation and different sizes

The Pattern Sorting Tool is able to find a trained pattern no matter its position and orientation. Moreover, the algorithm can detect a reference pattern even when its dimensions are not fixed.



Robustness against out-of-plane rotations

The Pattern Sorting Tool is able to cope with perspective distortions (i.e. out-of-plane pattern rotations). This capability is absolutely needed when the objects to inspect have variable and inconsistent positioning (e.g. boxes on a conveyor belt) or have irregular shapes (non-planar objects).



Partially occluded pattern detection

Partially occluded patterns do not represent an issue for the PST. By leveraging its ability to extract and match several pattern features simultaneously, the algorithm is able to identify patterns even when partially damaged or occluded.



Robustness against light variations

The Pattern Sorting Tool extracts and matches features with minimum dependency to lighting. This guarantees an extremely reliable pattern detection even when the surrounding lighting is variable and inconsistent.

PATTERN DATABASE MANAGER (PDM)

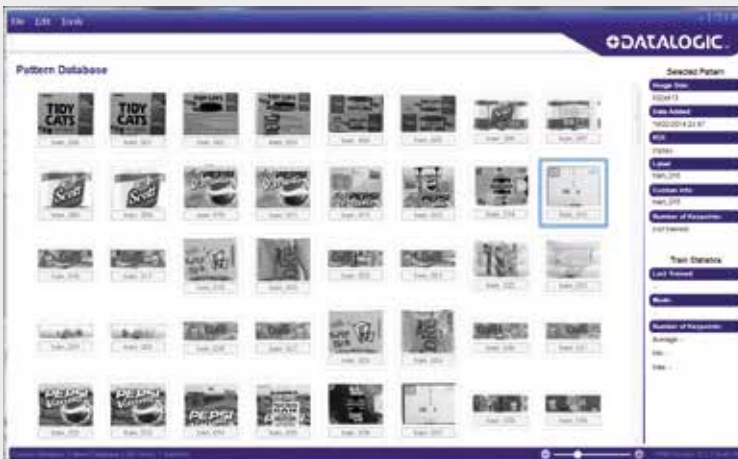

With the new Pattern Database Manager (PDM) software application, users can easily create new databases or edit existing ones. Adding, modifying or deleting patterns is quick and intuitive as well as linking the whole database to one or more IMPACT .vp files.



UNDERSTANDING MACHINE VISION

MACHINE VISION

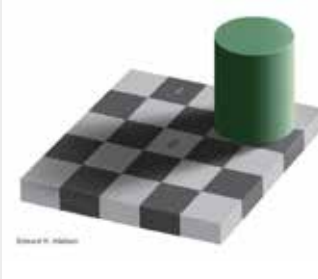

Machine vision is different from human vision. Human brain infers what eyes cannot see. It can create composite images from multiple angles.



A and B squares seem to have different colors (i.e. A darker than B) but actually they do not. By removing surroundings, they have exactly the same greylevel and this is how they are perceived by an electronic eye.



A machine vision monochromatic (greyscale) image will only show differences in contrast. So, a good image for machine vision is different than for human vision.

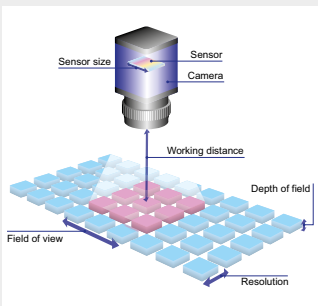

MACHINE VISION GLOSSARY

Working Distance (WD): The distance from the front of the lens to the object when in sharp focus.

Field-of-View (FOV): The imaging area that is projected onto the imager by the lens. Note that most imagers used today provided a 4:3 aspect ratio (4 units wide and 3 units high).

Depth-of-Field (DOF): The range of the lens-to-object distance over which the image will be in sharp focus. Note that the shorter a lens' focal length is, or the more closed a lens' aperture is, the greater the available depth of field.

Resolution: The ability of an optical system to distinguish two features that are close together. Note that both imagers and lenses have their own respective resolutions. Always consider the benefits of better camera resolution, but lens resolution is nearly always better than needed for most factory applications.

CAMERA SELECTION

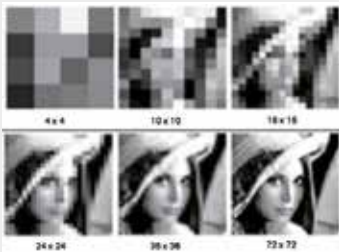

Resolution

Resolution is a measure that identifies the camera capability to acquire image details. Higher resolution means more image detail. The convention is to describe the pixel resolution with the set of two positive integer numbers, where the first number is the number of pixel columns (width) and the second is the number of pixel rows (height), for example as 640 by 480. Another popular convention is to cite resolution as the total number of pixels in the image, typically given as number of megapixels, which can be calculated by multiplying pixel columns by pixel rows.

Acquisition (frame) rate

Frame rate is the frequency (rate) at which a camera is able to acquire consecutive images (area scan camera) or consecutive lines (line scan camera). Frame rate is typically expressed respectively in Frames Per Second (FPS) or Thousands of Line per Second (KHz).

Greyscale VS Color

Most of machine vision applications are solved using greyscale cameras. In a greyscale image the value of each pixel represents the light intensity information. The color depth identifies the number of different intensities (i.e. shades of grey) that can be detected by every image pixel. Color depth is typically expressed in bits or greylevels (e.g. 8 bits = 256 different shades of grey).

8 bit(256 greylevels)	0	26	51	77	102	128	153	179	204	230	255

On the contrary color images contain 24 bits of information per pixel (as opposed to a greyscale's 8 bits), thus giving a color camera 3x more dynamic sensitivity. Note that most color cameras actually use a grayscale imager with a Bayer Filter. Intensity passing through 2x2 pixel grids are interpreted and converted into a color image. Note that there are twice as many green pixels since the human eye is most sensitive to green.



LENS SELECTION

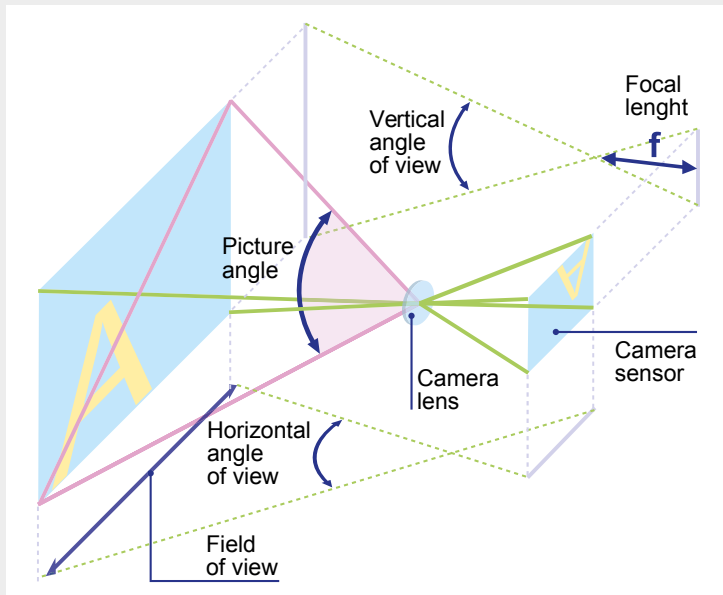

Focal Length:

The focal length of a lens is defined as the distance from the optical center of the converging lens to the focal point, which is located on the imager, when 'in focus'. Units are typically in mm.

Aperture (f-stop):

The ratio of the focal length of the lens to its effective diameter. Shown as f-stop or f/f . Each f-stop would allow either 1/2x or 2x light compare to the next f-stop. A larger aperture opening results in a smaller f-stop value. Note that the more closed a lens' aperture is, the greater the depth of field.

S-MOUNT



S-Mount lenses feature male M12 thread with 0.5 mm pitch on the lens and a corresponding female one the lens mount. Most commonly used with 'remote-head' cameras or with very compact devices like Vision Sensors.

C-MOUNT



C-mount lenses provide a male thread which mates with a female thread on the camera. Most common standard, used with VGA resolution (640x480) up to 2 Megapixel cameras.

F-MOUNT



F-Mount lenses feature a three lug bayonet mount with a 44 mm throat and a flange to focal plane distance of 46.5 mm. Mainly used for high resolution cameras.

CONVENTIONAL VS TELECENTRIC LENSES

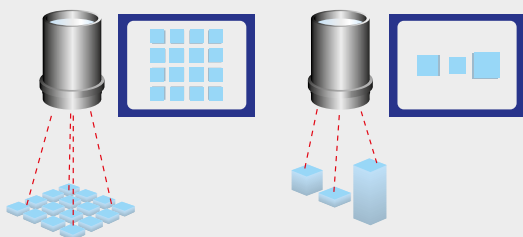

Conventional Lenses view in a conical shape and generally produce magnification errors in radial bands about its center, thus producing magnification errors when viewing objects at different distances.

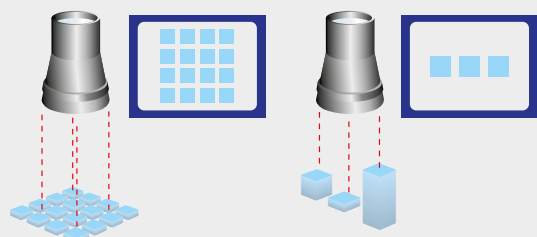

Telecentric Lenses offer constant magnification with change in distance. These lenses are used for high-precision measurement of objects at different depths.

UNDERSTANDING MACHINE VISION

BASIC CONCEPT

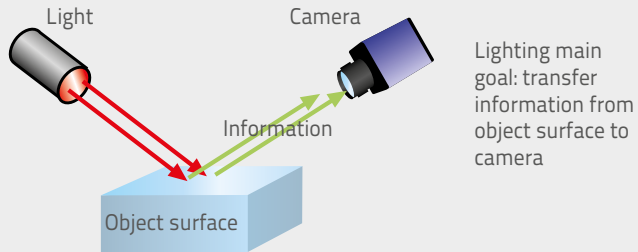

THE IMPORTANCE OF MATERIALS

Material and surface finishing are important as well.



Surface reflectivity difference between the machined aluminum and cast aluminum (direct vs. scattered light)

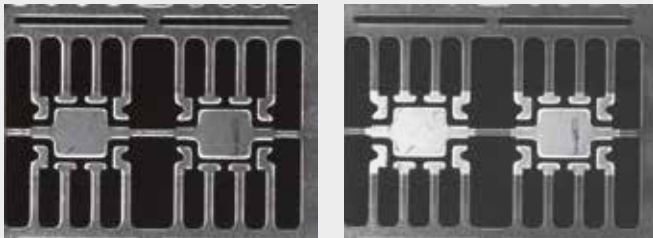

Copper & Silver terminals: red illuminator (on the left), blue illuminator (on the right)

LIGHT INTERACTIONS

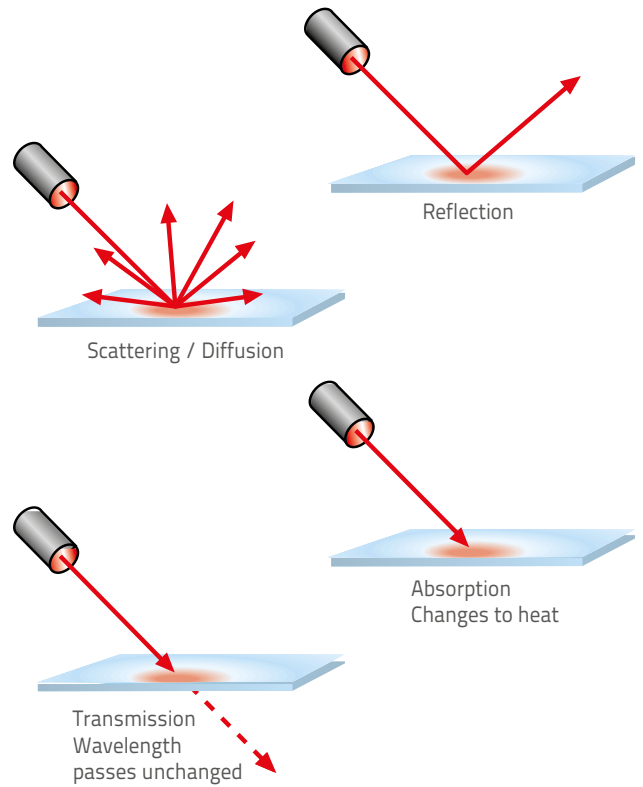

In machine vision the main goal is to optimize the contrast between the features that must be inspected and their background. In order to do so, light interaction principles must be taken into consideration and properly exploited. The characteristics of an object will determine how light is reflected or absorbed.

LIGHTING TECHNIQUES

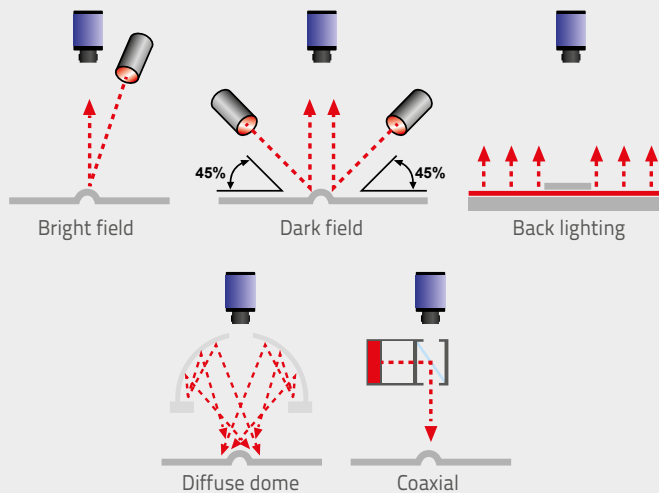

THE IMPORTANCE OF COLORS

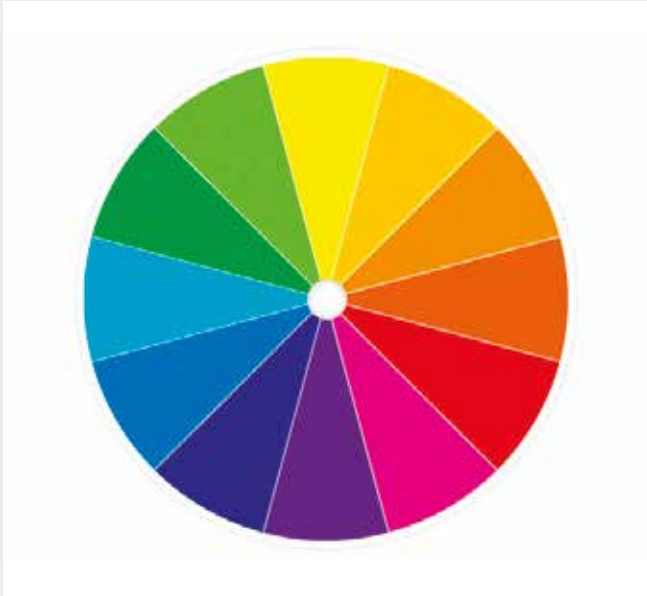

Colors affect acquired images even when monochrome cameras are used. Rule of thumb:

- In order to brighten, use same color lighting as compared to the object
- In order to darken, use opposite color lighting as compared to the object

LIGHTING COLOR

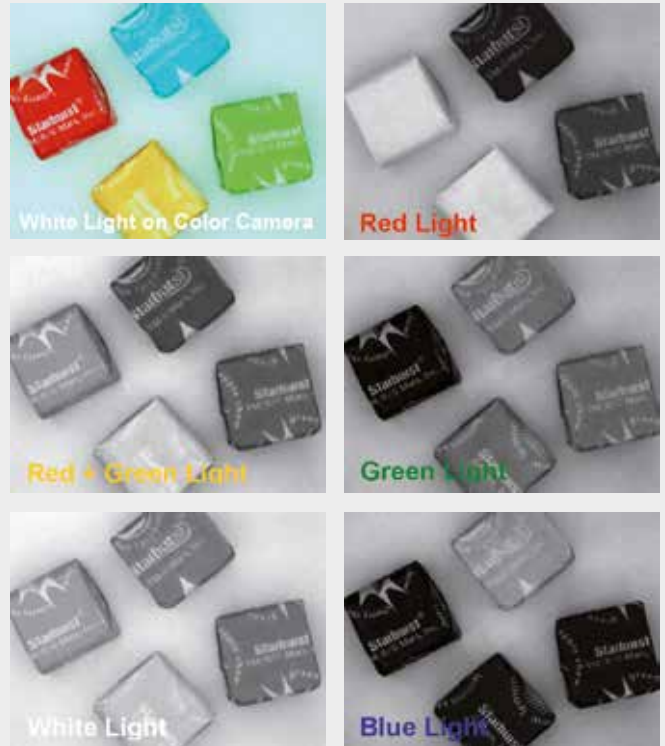

CONSTRAINTS

camera & lens
sharp cut filter R64

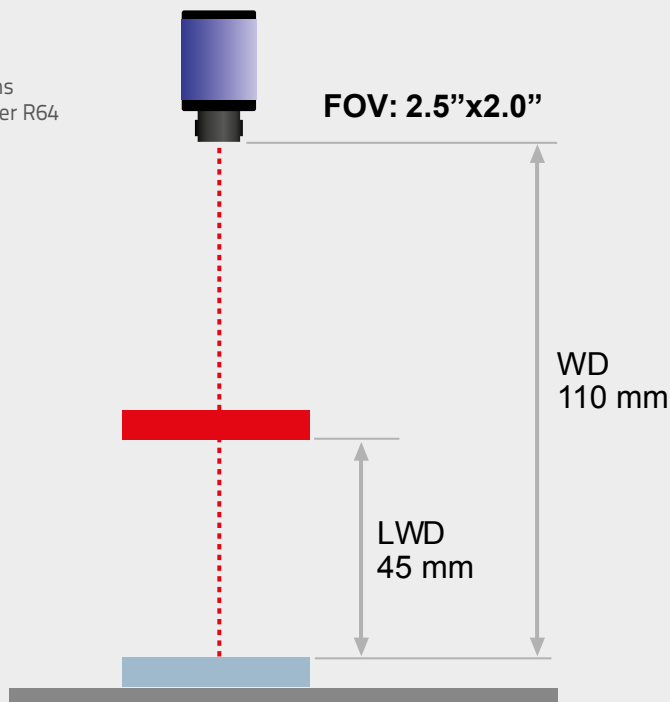

When evaluating a machine vision application, mechanical constraints must be carefully evaluated and considered since they may limit the lighting and lensing solutions.

Space (volume) constraints

- What space is available for lighting?

Speed of inspection

- Limits what lighting (strobed or static) and what inspection tools can be used

Environmental issues

- Specific IP rating requirements?

SMART CAMERAS

P-SERIES



- Cost effective compact Smart Camera Series
- Right-angle IP67 rated enclosure with rotating connectors
- VGA (640x480) or 1.3 MP (1280x1024) with color or grey-scale imagers
- Embedded interchangeable lenses and illuminators
- Built-in digital I/Os, Serial and Ethernet interfaces

The P-Series is an ultra-compact cost effective smart camera offering advanced machine vision functionalities in a fully embedded stand-alone device. The P-Series is available with gray-scale or color CMOS image sensors with two different resolutions: VGA and 1.3MP. Lenses and illuminators are fully interchangeable and can be mounted and replaced by the user. Five focal lengths and nine lighting options result in 90 different combinations delivering outstanding installation flexibility while offering superior image acquisition capabilities. The P-Series is powered by the IMPACT LITE software package. With more than 25 inspection tools, IMPACT LITE revolutionizes device programming by making the inspection configuration quick and intuitive. step by step.

A-SERIES



- Mid-range Smart Camera
- Right-angle IP67 rated enclosure
- VGA (640x480) grey-scale imager
- Built-in digital I/Os and Serial interface
- Gbit Ethernet Port

The A-Series is a stand-alone, general purpose and cost effective Smart Camera that can be installed even in harsh industrial environments thanks to its IP67 rated housing. The A-Series features a VGA (640x480) CCD imager, built-in discrete I/Os as well as Ethernet and Serial interfaces. Thanks to the ultimate programming flexibility offered by Impact software, the A-Series represents the answer to every machine vision need.

T-SERIES



- High performance Smart Camera series
- Right-angle IP67 rated enclosure
- Up to 5Mpix grey-scale imager
- Built-in digital I/Os and Serial interface
- Gbit Ethernet Port

The new T-Series smart camera provides customers with outstanding performance in an industrialized and compact package. Equipped with a powerful 1.1 GHz processor, the T-Series performance is exceptional in value and functionality. The T-Series comes in 3 different camera resolutions, VGA, 2 Mega-Pixel and 5 Mega-Pixel all in a sealed, industrially hardened enclosure for maximum protection. Combined with Impact software, the new generation T-series delivers the most rugged and versatile smart camera solution in the market today.

SMART CAMERAS



	P-SERIES	A-SERIES	T-SERIES
FORMAT	Right angle (with rotating connectors)	Right angle	Right angle
IMAGER	<ul style="list-style-type: none"> 640 x 480, 1/4" CMOS, 120 fps 1280 x 1024, 1/1.8" CMOS, 60 fps 	<ul style="list-style-type: none"> 640 x 480, 1/3" CCD, 60 fps 	<ul style="list-style-type: none"> 640 x 480, 1/3" CCD, 60 fps 1600 x 1200, 1/1.8" CCD, 15 fps 2448 x 2048, 2/3" CCD, 15 fps
IMAGE	8 bit gray-scale 24 bit color	8-bit gray-scale	8-bit gray-scale
LENS MOUNT	Embedded lenses	C-Mount	C-Mount
PROCESSOR	660 MHz DSP	800 MHz DSP	1.1 GHz DSP
ON-BOARD IMAGE BUFFERING	Up to 16	Up to 16	Up to 16
ON-BOARD PROGRAM STORAGE	256 MB flash	256 MB flash	256 MB flash
DEDICATED ON-BOARD OPTICALLY ISOLATED I/O	1 IN	1 IN / 1 OUT	1 IN / 1 OUT
CONFIGURABLE ON-BOARD OPTICALLY ISOLATED I/O	1 IN / 3 OUT	1 IN / 2 OUT	1 IN / 2 OUT
RS-232 SERIAL	▪	▪	▪
ETHERNET	▪	▪	▪
EXTERNAL BUTTON	▪	▪	▪
POWER REQUIRED	10 ... 30 Vdc 0.7 ... 0.2A	10 ... 30 VDC 1 ... 0.33 A	<ul style="list-style-type: none"> T40 10 ... 30 VDC 1 ... 0.33 A T47 10 ... 30 VDC 1.05 ... 0.35 A T49 10 ... 30 VDC 1.2 ... 0.4 A
DIMENSIONS	95 x 54 x 43 mm (3.7 x 2.1 x 1.7 in.) Connector @ 0° 75 x 54 x 62 mm (3.0 x 2.1 x 2.4 in.) Connector @ 90°	123 x 60 x 86 mm (4.84 x 2.36 x 3.41 in)	123 x 60 x 101 mm (4.84 x 2.36 x 3.98 in)
MECHANICAL PROTECTION	IP67	IP67	IP67
OPERATING TEMPERATURE	0°C ... +50 °C	0 °C ... +45 °C	0 °C ... +50 °C
HUMIDITY (NON-CONDENSING)	0 ... 90 %	0 ... 90 %	0 ... 90 %
CERTIFICATIONS	CE, CSA	CE, CSA	CE, CSA

VISION PROCESSORS

MX-E SERIES



- Multi-camera vision processors
- GigE Vision camera connectivity
- Three models with different processing capabilities
- Windows Embedded Standard 7®

Three different MX-E models are available, each featuring the ultimate Intel® multi-core chipsets: the entry-level cost effective MX-E20 supporting two PoE cameras, the mid-range MX-E40 and the high-end quad core MX-E80 both supporting two or four PoE cameras. All the MX-E series models are available either with PNP or NPN digital I/Os delivering extended connectivity to any PLC brand. Three processor models covering different performance levels, two or four GigE camera ports and two digital I/O options result in ten different hardware configurations covering even the most challenging applications in Automotive, Electronics and Food & Beverage.

Powered by IMPACT, the MX-E Series is the ideal solution for highly demanding multi-camera vision inspections.

MX-U SERIES



- Multi-camera vision processors
- USB3.0 Vision camera connectivity
- Three models with different processing capabilities
- Win 7® operating systems

The MX-U Series family of Industrial Vision Processors offers superior image processing capabilities and outstanding inspection flexibility. The MX-U Series supports the USB 3.0 Vision interface standard for high speed digital camera communication. Featuring the latest Intel® chipsets, the MX-U Vision Processors deliver outstanding computing performance at affordable prices. Three different models are available according to the application requirements: the entry-level cost-effective MX-U20 supporting two cameras, the mid-range MX-U40 powering four cameras, the high-end quad core MX-U80 delivering maximum processing speed to four cameras.

A single vision processor supports multiple independent cameras resulting in application flexibility while dramatically reducing the cost per inspection point. Powered by IMPACT Software, the MX-U Series offers quick and easy application prototyping and deployment as well as seamless integration.

VISION PROCESSORS





	MX-E SERIES			MX-U SERIES		
	MX-E20	MX-E40	MX-E80	MX-U20	MX-U40	MX-U80
CPU	Intel® Celeron 1047UE 1.4 Ghz – dual core	Intel® Celeron 1020E 2.2 Ghz – dual core	Intel® Core i7 3615QE 2.3 Ghz – quad core	Intel® Celeron 1047UE 1.4 Ghz – dual core	Intel® Celeron 1020E 2.2 Ghz – dual core	Intel® Core i7 3615QE 2.3 Ghz – quad core
SYSTEM MEMORY	4 GB DDR3 RAM		8 GB DDR3 RAM	4 GB DDR3 RAM		8 GB DDR3 RAM
STORAGE	60 GB SATA SSD (MLC)		128 GB SATA SSD (MLC)	60 GB SATA SSD (MLC)		128 GB SATA SSD (MLC)
GRAPHICS	Intel® HD 3000 (1920x1200 resolution) – DVI			Intel® HD 3000 (1920x1200 resolution) – DVI		
CAMERA INTERFACE	2x 1000 Mbps Base-T, PoE camera ports (Up to 7 W per channell)	2 o 4x 1000 Mbps Base-T, PoE camera ports (Up to 7 W per channell)		2x USB3.0 ports – 5 Gb/s max 1 A Max per connection	4x USB3.0 ports – 5 Gb/s max 1 A Max per connection	
CAMERA IMAGER LIMIT	2Mpix or lower	None		2Mpix or lower	None	
NETWORK INTERFACE	2x10/100/1000 Mbps Base-T, LAN ports			2x10/100/1000 Mbps Base-T, LAN ports		
SERIAL COMMUNICATIONS	1x RS-232 serial port			1x RS-232 serial port		
KEYBOARD/MOUSE	4x USB3.0 ports			2x USB3.0 ports	1x USB2.0 port	
COMM CONNECTIVITY	Supports Ethernet/IP, Modbus TCP and OPC			Supports Ethernet/IP, Modbus TCP and OPC		
I/O	<ul style="list-style-type: none"> 32x opto-isolated digital inputs e outputs (16 IN - 16 OUT), NPN or PNP 			<ul style="list-style-type: none"> 16x opto-isolated digital inputs 16x opto-isolated digital outputs - current sinking 		
OPERATING SYSTEM	Windows Embedded Standard 7			Windows Embedded Standard 7		
POWER REQUIREMENTS	24 VDC +/- 25% (5.5 A @ 24 VDC)			24 VDC +/- 25% (5.5 A @ 24 VDC)		
DIMENSIONS	270 (H) x 130 (W) x 255 (D) mm 10.6 (H) x 5.1 (W) x 10 (D) in.			270 (H) x 130 (W) x 255 (D) mm 10.6 (H) x 5.1 (W) x 10 (D) in.		
OPERATING TEMPERATURE	0 to +55° C (+32 to +131° F)			0 to +55° C (+32 to +131° F)		
HUMIDITY	10 to 90% (non-condensing)			10 to 90% (non-condensing)		
MECHANICAL PROTECTION	IP20			IP20		
CERTIFICATIONS (SAFETY COMPLIANCE)	CE, c-UL-us			CE, c-UL-us		

DIGITAL CAMERAS

E100 SERIES GIG-E CAMERAS

	GRAYSCALE MODEL	COLOR MODEL	RESOLUTION	IMAGER	SHUTTER	FRAME RATE (FPS)	PoE
	E101	E101C	640 x 480	1/4" CMOS	Global	300	▪
	E151	E151C	1280 x 1024	1/2" CMOS	Global	75	▪
	E181	E181C	1920 x 1200	2/3" CMOS	Global	48	▪
	E198	E198C	2590 x 2048	1" CMOS	Global	20	▪

M-SERIES GIG-E CAMERAS

	GRAY-SCALE MODEL	COLOR MODEL	RESOLUTION	IMAGER	SHUTTER	FRAME RATE (FPS)	PoE
	M100	M100C	640 x 480	1/4" CCD	Global	100	▪
	M110	M110C	640 x 480	1/3" CCD	Global	90	▪
	M115	M115C	659 x 494	1/2" CCD	Global	100	▪
	M125	M125C	782 x 582	1/2" CCD	Global	75	▪
	M150	M150C	1296 x 966	1/3" CCD	Global	30	▪
	M180	M180C	1628 x 1236	1/1.8" CCD	Global	20	▪
	M190	M190C	2048 x 1088	2/3" CMOS	Global	50	▪
	M195	M195C	2048 x 2048	1" CMOS	Global	25	▪
	M197	M197C	2592 x 1944	1/2.5" CMOS	Rolling	14	▪
	M200	M200C	659 x 494	1/3" CCD	Global	70	
	M202	M202C	659 x 494	1/2" CCD	Global	79	
	M250	M250C	1280 x 960	1/3" CCD	Global	32	
	M295	M295C	1628 x 1236	1/1.8" CCD	Global	28	
	M300	M300C	648 x 488	1/3" CCD	Global	210	
	M330	M330C	1004 x 1004	2/3" CCD	Global	60	
	M350	M350C	1608 x 1208	1" CCD	Global	35	
	M390	M390C	2448 x 2050	2/3" CCD	Global	17	

U-SERIES USB3.0 CAMERAS

	GRAY-SCALE MODEL	COLOR MODEL	RESOLUTION	IMAGER	SHUTTER	FRAME RATE (FPS)
	U100	U100C	658 x 492	1/4" CCD	Global	120
	U101	U101C	640 x 480	1/4" CMOS	Global	750
	U110	U110C	658 x 492	1/3" CCD	Global	90
	U150	U150C	1294 x 964	1/3" CCD	Global	30
	U151	U151C	1280 x 1024	1/2" CMOS	Global	200
	U180	U180C	1624 x 1234	1/1.8" CCD	Global	20
	U181	U181C	1920 x 1200	2/3" CMOS	Global	150
	U190	U190C	2048 x 1088	2/3" CMOS	Global	165
	U195	U195C	2048 x 2048	1" CMOS	Global	90
	U197	U197C	2590 x 1942	1/2.5" CMOS	Rolling	14
	U198	U198C	2590 x 2048	1" CMOS	Global	60

MX-E SERIES LINE-SCAN GIG-E CAMERAS

	MODEL	RESOLUTION	MAX. LINE RATE	PIXEL SIZE	C-MOUNT	F-MOUNT	M42-MOUNT
	M565	2048	48 KHz	7x7 µm	▪	▪	
	M570	4096	24 KHz	7x7 µm		▪	
	M575	6144	17KHz	7x7 µm		▪	▪
	M580	8192	12KHz	3.5x3.5 µm		▪	▪

SPECIALTY CAMERAS

SPECIALTY	CONNECTIVITY	RESOLUTION	IMAGER	MONOCHROME/COLOR	ACQUISITION RATE	LENS MOUNT
JAI						
Remote Head	GigE Vision	656 x 494	1/3" CCD	Monochrome	120 fps	C-Mount
UV Sensitive	GigE Vision	1380 x 1040	1/2" CCD	Monochrome	16 fps	C-Mount
8 MegaPixel	GigE Vision	3296 x 2472	4/3" CCD	Monochrome	10 fps	F-Mount
16 MegaPixel	GigE Vision	4872 x 3248	43.3mm CCD	Monochrome	3 fps	F-Mount
20 MegaPixel	USB3.0	5120 x 3840	41 mm CMOS	Monochrome	16	F-mount
3 CCD Color	GigE Vision	1392 x 1040	1/2" CCD	Color	20 fps	C-Mount
3 CCD Color	GigE Vision	1620 x 1236	1/1.8" CCD	Color	15 fps	C-Mount
BASLER						
High speed	GigE Vision	1K x 1K	1/2" CCD	Monochrome - Color	100 fps	C-Mount
High speed	GigE Vision	1600 x 1200	2/3" CCD	Monochrome - Color	50 fps	C-Mount
High speed	GigE Vision	1920 x 1080	2/3" CCD	Monochrome - Color	50 fps	C-Mount
High speed	GigE Vision	2330 x 1750	1" CCD	Monochrome - Color	25 fps	C-Mount
High speed	GigE Vision	3 x 2098	Tri-linear CCD	Color Linescan	9.2 KHz	F-Mount
SVS-VISTEK						
IP67	GigE Vision	640 x 480	1/3" CCD	Monochrome - Color	124 fps	C-Mount
IP67	GigE Vision	640 x 480	1/2" CCD	Monochrome - Color	125 fps	C-Mount
IP67	GigE Vision	640 x 480	1/4" CCD	Monochrome - Color	150 fps	C-Mount
IP67	GigE Vision	780 x 580	1/2" CCD	Monochrome - Color	86 fps	C-Mount
IP67	GigE Vision	1024 x 768	1/3" CCD	Monochrome - Color	47 fps	C-Mount
IP67	GigE Vision	1280 x 960	1/3" CCD	Monochrome - Color	30 fps	C-Mount
IP67	GigE Vision	1360 x 1024	1/2" CCD	Monochrome - Color	25 fps	C-Mount
IP67	GigE Vision	1360 x 1024	2/3" CCD	Monochrome - Color	34 fps	C-Mount
IP67	GigE Vision	1600 x 1200	1/1.8" CCD	Monochrome - Color	26 fps	C-Mount
IP67	GigE Vision	2448 x 2050	2/3" CCD	Monochrome - Color	10 fps	C-Mount
16 MegaPixel	GigE Vision	4864 x 3232	43.2 mm CCD	Monochrome	11	M58x0.75

ACCESSORIES



OPTICS AND FILTERS



ILLUMINATORS

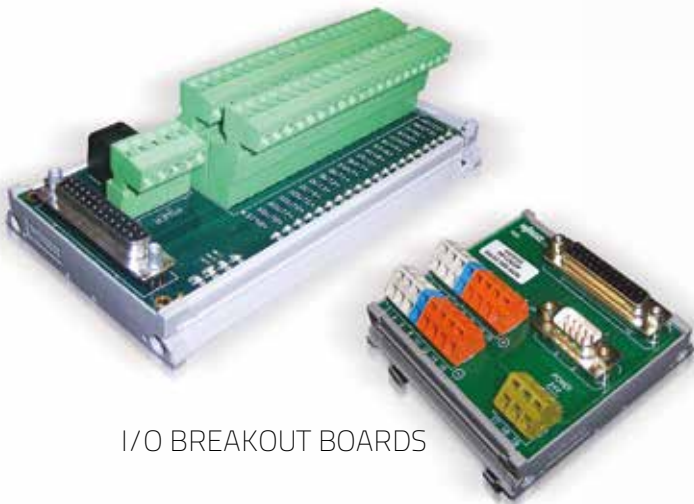

I/O BREAKOUT BOARDS



OTHER ACCESSORIES

Datalogic Automation is able to provide a broad and comprehensive range of accessories to allow customers and partners to fully leverage the power and capabilities of its machine vision systems. A wide and complete portfolio of lenses, filters, illuminators, enclosures, breakout boards, etc... either designed and manufactured internally or coming from selected leading machine vision suppliers.

OPTICS AND FILTERS

- Standard, flat field and telecentric lenses available in C-Mount and F-Mount formats
- Lens filters

ILLUMINATORS

- Different technologies such as LED, fluorescent, xenon, halogen, laser, etc...
- Different colors, formats and shapes
- Backlighting, bright-field and dark-field illuminators

I/O BREAKOUT BOARDS

- Standard I/O boards
- Expansion I/O boards
- Connectivity to industrial fieldbus

OTHER ACCESSORIES

- Camera enclosures
- Industrial monitors
- Cables
- Mounting hardware

WWW.DATALOGIC.COM

- FREE full-feature trial software
- FREE download product literature, technical specifications and drawings
- FREE online training material to do at your own pace
- FREE IMPACT application videos and sample programs
- FREE MV initial application evaluation



BASIC - 1.5 DAYS

- What is machine vision
- Vision products overview
- Application examples and proven solutions
- DataVS training
- I/O wiring of the hardware - basics
- VPM basic training

INTERMEDIATE - 2 DAYS

- VPM intermediate training
- CPM basic training.
- Application Specific training – attendees are requested to bring their parts to work on them

ON-SITE TRAINING

- Customized for Your Application, Location and Schedule
- Contact our Training Department for pricing

SUPPORT

- Phone support Mon to Fri, 8 to 5
- Email support – contact Datalogic Automation Application Engineering dept. at mvsupport@datalogic.com
- Complete Turn-key solutions with:
 - a. In-depth application evaluations
 - b. VPM and CPM programming
 - c. On-site installations

2025-2026 Financial Statement



HEADQUARTERS

Datalogic Automation Srl

Via Lavino, 265
40050 Monte San Pietro - Bologna - Italy
Tel: +39 051/6765611
info.automation.it@datalogic.com

BRANCHES AND SALES OFFICES

EUROPE BENELUX

Datalogic Automation Benelux

Newtonweg 3
4104 BK Culemborg - The Netherlands
Tel. +31 345/589489
info.automation.nl@datalogic.com

FRANCE

Datalogic Automation Srl

Succursale en France
Le Parc Technologique de Lyon
333 cours du 3ème Millénaire - Le Pôle
69800 Saint Priest
Tél. +33 (0)4/72476180
info.automation.fr@datalogic.com

GERMANY

Datalogic Automation Srl

Niederlassung Central Europe
Gottlieb-Stoll-Straße 1,
73271 Holzmaden
Tel. +49 7023 7453-100
info.automation.de@datalogic.com

ITALY

Datalogic Automation Italy

Via Lavino, 265
40050 Monte San Pietro - Bologna
Tel. +39 051/6765611
info.automation.it@datalogic.com

Via Taormina 1
20093 - Cologno Monzese (MI) Italy
Tel. +39 02 25151211
info.automation.it@datalogic.com

Via Le Gorrey, 10 11020, Donnas - Aosta
Tel. +39-0125-8128201
info.automation.it@datalogic.com

SPAIN

Datalogic Automation Iberia

Sucursal en España
C/ Frederic Mompou 4 esc A, 4º puerta 3ª
08960 Sant Just Desvern - Barcelona
Tel. +34 (0)93/4772059

NORDIC

Datalogic Automation ab

Höjdroergatan 21
21239 Malmö - Sweden
Tel. +46 (0)40/385000
info.automation.se@datalogic.com

UNITED KINGDOM

Datalogic Automation UK

Datalogic House
Dunstable Road, Redbourn - Hertfordshire
AL3 7PR
Tel. +44 (0) 1582 791750
info.automation.uk@datalogic.com

TURKEY

Datalogic ADC Turkey

Merkezi İtalya İstanbul Merkez Şubesi Süleyman
Seba Cad. No:48 BJK Plaza A. Blok Kat:4 D.44
34357 - İstanbul - Turkey
Tel. +90 212 396 1550
info.adc.tr@datalogic.com

NORTH AMERICA

Datalogic Automation Inc

511 School House Road
Telford, PA 18969-1196 - United States
Tel. +1-800-BAR-CODE or +1-215-723-0981
info.automation.us@datalogic.com

Datalogic Automation Inc MACHINE VISION

5775 W Old Shakopee Rd
STE 160, Bloomington, MN 55437
United States
Tel. +1-952-996-9500
info.automation.us@datalogic.com

SOUTH AMERICA

Datalogic Brazil

Avenida Olivio Roncoletta, 465
Bairro Vila Hortolandia Jundiã (SP), Brazil
Tel. +55 11 29232600
info.automation.br@datalogic.com

APAC

Australia-New Zealand

Datalogic Automation Pty Ltd

Unit 130, 45 Gilby Road
Mt Waverley - Victoria, 3149 - Australia
Tel. +61 (0)3/95589299
info.automation.au@datalogic.com

CHINA

Datalogic Automation Asia

2nd Floor, 10 Building, Dayuan Industrial Zone,
No.1, Pingshan 1st Road,
Liuxuan Blvd. Xili, Nanshan District,
518054, Shenzhen, China
Tel: +86 (0)755-8629 6779
info.automation.cn@datalogic.com

Suite 1301, Hua Rong Plaza,
1289 South Pudong Road, Pudong District
Shanghai 200120
Tel: +86 (0)21-5836 6692
info.automation.cn@datalogic.com

Floor 20, Room 2019, Building 2,
16 West Nan San Huan Road
Fengtai District, Beijing
Tel: +86 (0)10-8757 6375
info.automation.cn@datalogic.com

1202, Excellence Build, 128 Yanji Road,
Shibei District, Qingdao, China
Tel: +86 (0)532 55787889

JAPAN

Idec Auto-Id Solutions Corporation

8-10, Shioe 5-chome, Amagasaki Hyogo,
Japan 661-0976
Tel. +81-6-7711-8880
www.idec.com

Rev. 09_01/2016



9C512100E

Product and Company names and logos referenced may be either trademarks or registered trademarks of their respective companies. We reserve the right to make modifications and improvements.



www.datalogic.com